

EMULE

MINI LOADER Battery powered



TECHNICAL DATA

Motor Type	Pmac (rotating magnetic)
Drive System	Hydraulic wheel motors
Revolutions (RPM)	2500
Battery Type	Lead acid Battery
Voltage (V)	36
Battery Capacity (Ah)	240
Drive Type	Hydraulic 4WD
Speed (km/H, depend of Tires)	0- 6 km/h (proportional)
Breakout capacity (kg)	400
Load capacity (kg)	450 (with counterweight)
Tractive Force (kg)	440
Hydraulic Drive (liter/min)	18,5
Hydraulic tank capacity (liter)	15
Standard Tire	4.00-8 Forklift solid
Steering type	Skid Steer
Dimensions L x W x H (mm)	1525x740x1250
weight (kg)	850



990 lb
LOAD
CAPACITY



5,7 KW
MOTOR
OUTPUT



80,40 in
HEIGHT HINGE
POINT



100 % ÉLECTRIC
ZERO EMISSION

TOOLS & ATTACHMENTS

A	Hydraulic Manure Forks with Clamp
B	Set Pallet Forks
C	Bucket with Grab
D	Bucket



DIMENSIONS

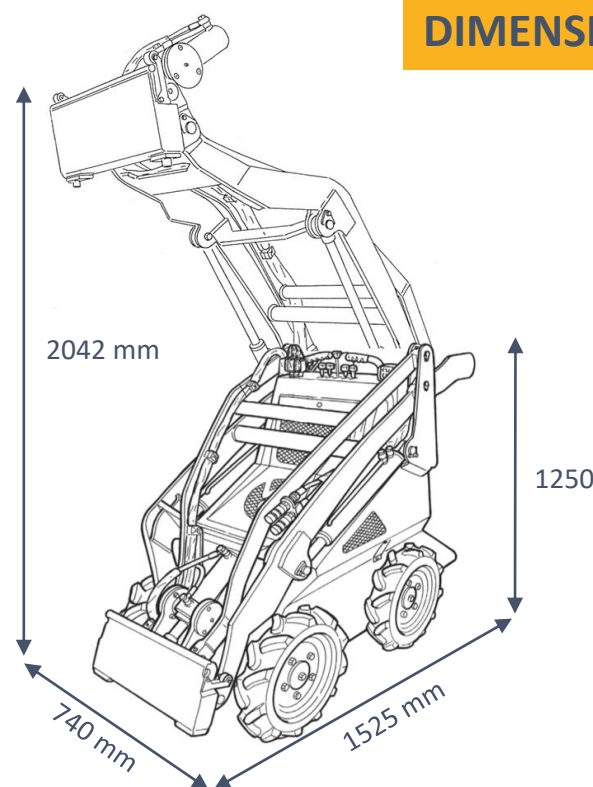

EASIER FASTER SAFER

